

MATERIAL PROPERTIES

Parts	Description	Material	Remark
	Jack Body	Polyamide	Black
	Fibre Washer (2 Nos.)	Vulcanized Fibre	Black
	Metal Nut (3/8" x 20TP1)	Brass	Chrome Plated
	Bezel	PP	Black
	Metal Contact	Nickel Silver	Tin Plated

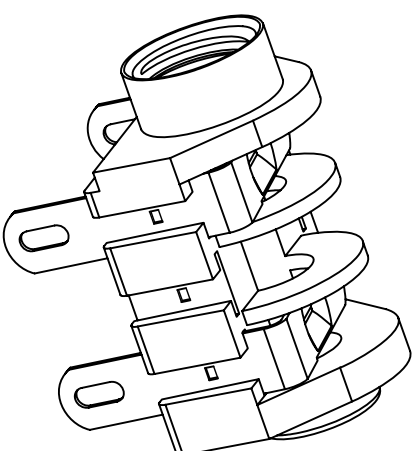

ISOMETRIC VIEW

DIMENSIONS IN MILLIMETERS  
3rd ANGLE PROJECTION  
SCALE: N.T.S.

SUPPLY NUTS, BEZELS AND WASHERS AS LOOSE PARTS

DRAWN	PYQ	MATERIAL:	SEE TABLE
CHECKED	PCS	FINISH:	AS MOULDED
ISSUE	1	1st DRAWN	13/0614
AMEND		DATE	

TOLERANCES  
NO DECIMAL PLACE ± 1.0  
1 DECIMAL PLACE ± 0.5  
2 DECIMAL PLACES ± 0.1  
DIAMETER HOLES ± 0.1  
ANGLES ± 1/2 DEGREE  
(UNLESS OTHERWISE STATED)



TITLE: 6:35 PHONE JACK, SOLDER TAG/BNB  
DRWG NO: JT-4040

